



brookfield industries, inc.
99 West Hillside Ave
Thomaston, CT 06787
T: 860.283.6211, F: 860.283.6123
www.bfimfg.com



NB-4100-1 Sliding Door Operator

Description:

The **NB-4100-1** has been designed, tested and is manufactured by **brookfield industries, inc.** for use on industrial sliding doors/ radiation sliding doors that require horizontal operating forces up to 300 lbs, variable speeds up to 13 inches/sec. The **NB-4100-1** can move doors across practically any opening width specified.

Power is supplied from a ¼ hp DC high torque gearmotor and transferred to linear motion through a steel reinforced, polyurethane timing belt supported by a *linear guide tracking system*, which keeps the belt from twisting and assures it is properly meshed into the pulleys at all times. Once the adjustable take-up end of the belt is set with the proper pretension, the **NB-4100-1** becomes a reliable, maintenance free door operator that needs no lubrication. The **NB-4100-1** with its lightweight aluminum construction is much easier to install, is more corrosion resistant and is heavier duty than other operators in the marketplace.

Door activation is via a (3) position-keyed switch.

Manual operation is provided by disconnecting the operator from the door by pulling down a spring-loaded pin.

Ratings:

The Peak Horizontal and Continuous Horizontal Forces are those operating forces required to respectively get the door system moving and to keep it moving at the required linear speed. The total door weight shall be supported by an independent door hanger system or other roller elements and shall not be supported by the **NB-4100-1 linear guide tracking system**. *The NB-4100-1 can be expected to operate at the ratings specified below, provided the linear guide tracking system is installed collinear with the door hanger centerline and the door hanger system operates without bind.*

Peak Horizontal Operating Force =	300 lbs (1335N)*
Continuous Horizontal Operating Force =	200 lbs (890N)**
Maximum Door Weight =	6000 lbs(2724kg)***
Life Cycles=	100,000 minimum
Door Travel Range=	Unlimited
Maximum Linear Speed=	13 inches/sec(33 cm/sec)

*consists of acceleration forces and static frictional forces

**consists of dynamic frictional forces

*** may operate at max. weight if and only if the Peak Horizontal and the Continuous Horizontal Operating Forces have not been exceeded.

Specification:

- 1) **Supply voltage:** 115VAC +/- 10% (230VAC for European service) 50/60 Hertz single phase. In-Line circuit breakers supplied with motor control. Surge protection, line filters, and EMI ferrites shall be included.
- 2) **Current Consumption:** maximum 12 amperes.
- 3) **Activation/Entrapment:**
Door activation shall be via a (3) position-keyed switch. Safety features (Entrapment per UL 325) include the following:
 - a. A maintained contact (continuous pressure) open and close (3) position-keyed switch that is spring return to stop in both directions.
 - b. A tape switch (not supplied) input that when activated on the closing side of the door, will rapid stop the door and override the (3) position keyed switch in the closing direction.



brookfield industries, inc.

99 West Hillside Ave

Thomaston, CT 06787

T: 860.283.6211, F: 860.283.6123

www.bfimfg.com

- c. Adjustable end of travel limit switches (supplied) that will override the (3) position-keyed switch.
 - d. **Forward and reverse torque adjustment:** via current limit trimpot settings on the Motor Control to adjust the operating torque in order to comply with the entrapment protection requirements of UL 325. This eliminates the need for unreliable and hard to adjust manual clutches or electromagnetic clutches that are not designed for slippage or stall applications.
- 4) **Motor Control:** shall be a full-wave, four quadrant, regenerative, 90 VDC variable speed control with the following functions:

FWD/REV maximum speed	FWD/REV current limit	IR compensation
FWD/REV acceleration/deceleration	1% speed regulation	50:1 speed range
 - 5) **Speed Control:** A means of controlling independent forward and reverse speeds from 0-100%.
 - 6) **Motor:** 3/4 hp permanent magnet 90 volt DC motor 1750 RPM TENV.
 - 7) **Overload protection:** 15 amp in-line fuse to the 110 VAC power supply of the Motor Control and by properly setting the DC current limiting trimpots.
 - 8) **Drive train:** Wormgear reduction shall be 20:1 with a 1.75" center distance. Rotary to linear motion shall be accomplished with a 1" wide x 1/2" pitch steel reinforced, polyurethane, open-ended timing belt. The timing belt shall be attached to a *linear guide tracking system*, which keeps the belt from twisting and assures it is properly meshed into the pulleys at all times. One (18 tooth) pulley shall be attached to the output shaft of the wormgear. The 2nd (18 tooth) pulley shall be attached to the adjustable take-up end of the belt.
 - 9) **Linear guide tracking system:** Consists of a mounting plate and (4) open, self-lubricating, linear plain bearing slides, riding on continuously supported round bars. The mounting plate shall also provide attachment for the timing belt and for the pull down pin.
 - 10) **Door disconnect/ Manual operation:** A spring loaded quick release pull down pin disconnects the operator from the door to allow for manual operation per UL 325 during power interruption.
 - 11) **Enclosure:** NEMA 1 vented enclosure of sufficient size (20" x 16 x 6-5/8") to house the PLC, motor control, speed pots, battery backup system and terminal strip hookups. Enclosure shall have separate penetrations for supply voltage, safety sensors, push buttons, motor and positioning transducer hookups. For 230VAC European service, the transformer shall be housed in a separate 16" x 20" x 6-5/8" NEMA 1 vented enclosure. All penetrations shall be drilled for 3/4" conduits or the equivalent metric size for European installations.
 - 12) **Materials:** Aluminum 6061-T651&T-6, AISI 1018 cold rolled steel, grade 5 bolting or better.
 - 13) **Structural:** Raw material shall be properly "sized" to support all design loads by using analysis methods that are considered industry standards. Allowable stresses shall be in accordance with AISC ASD 9th ed.
 - 14) **Mounting hardware:** the NB-4100 shall be mounted with 3/8" grade 5 diameter bolts with compatible washers and lock washers. Hardware must also be properly tightened with adequate thread engagement.
 - 15) **Finish:** all exposed carbon steel surfaces shall be prime painted.
 - 16) **Functionality test:** each NB-4100 is cycle tested in position for 24 hrs. prior to shipment. Each unit is checked for leaks and that all I/O are functioning properly.
 - 17) **Installation:** The NB-4100 shall be installed per instructions in the manual and the applicable drawings.
 - 18) **Battery Backup (optional):** Opens the door during power interruption only. (2) 12VDC, 7.0 Ah battery with float chargers and test switch shall be assembled in a grounded and vented 6" x 12" x 14" NEMA 1 enclosure. (3) holes are provided at the top of the enclosure each for 3/4" conduit or the metric equivalent for European installations. The first shall be used for a 110V AC line from the power source, the 2nd for a 110VAC hookup to the door operator and the 3rd for a 12VDC hookup to the door operator. An end of travel limit switch shall also be provided.

Tolerances	Decimal 1/8	Fractional +/- mm	Angular +/- mm
------------	-------------	-------------------	----------------

Rev.	Revision note	Date	Sign	Check
2	REVISED NOTES	2/19/16		

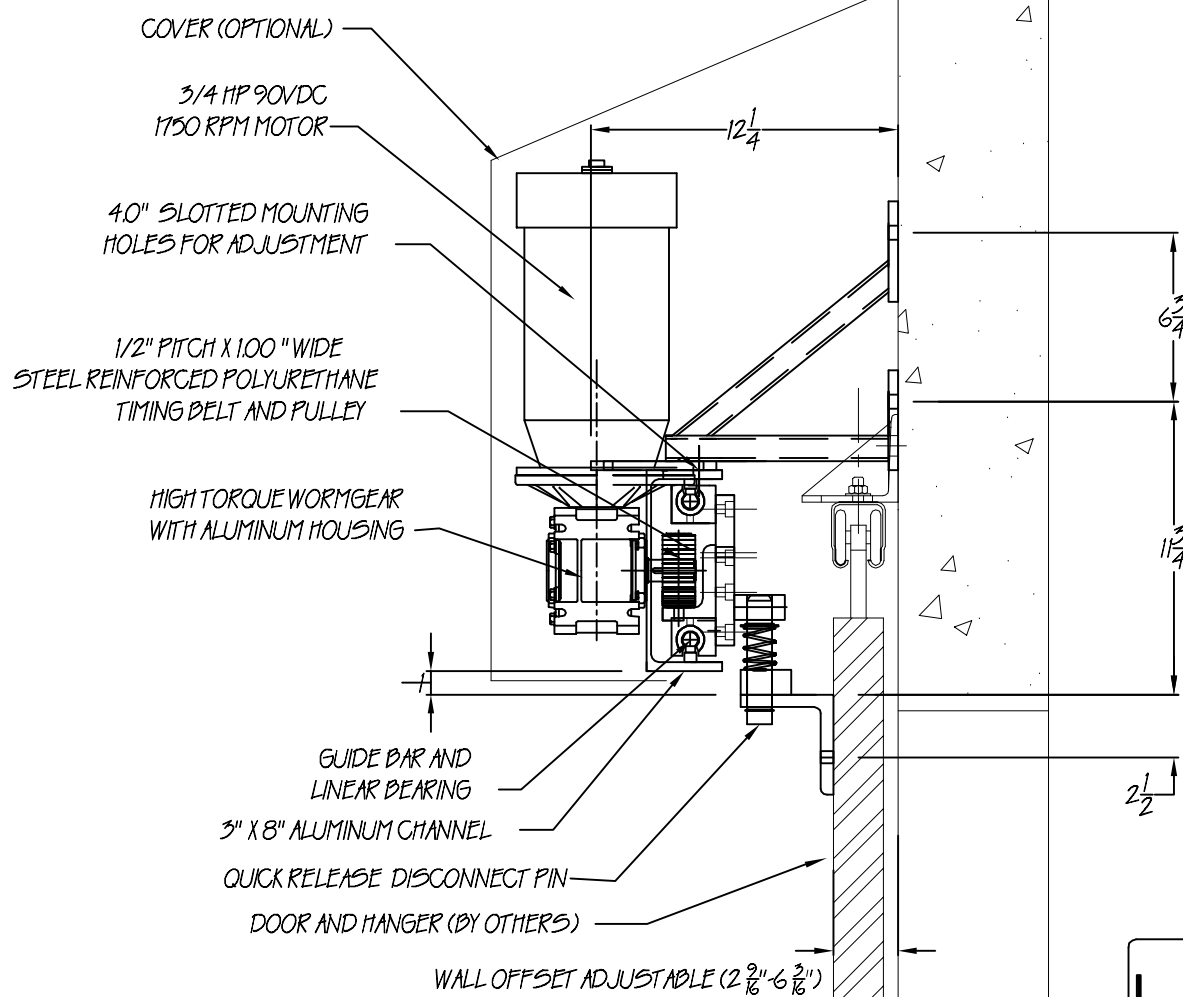

	NB-4100-1 SLIDING DOOR OPERATOR		Drawn by KPK
			Checked by XXX
	Material	Date 1/20/03	Scale 1:1
	SIDE ELEVATION / INSTALLATION DWG		
brookfield industries inc. 99 West Hillside Ave.: Thomaston, CT P: (860) 283-6211 F: (860) 283-6123 info@brookfieldindustries.com		www.bfimfg.com Drawing No/File Name DO2003R1	

Tolerances	Decimal +/- .0005	Fractional +/- .001	Angular +/- .01
------------	-------------------	---------------------	-----------------

Rev.	Revision note	Date	Sign	Check
4	REVISE NOTES	5/19/16		

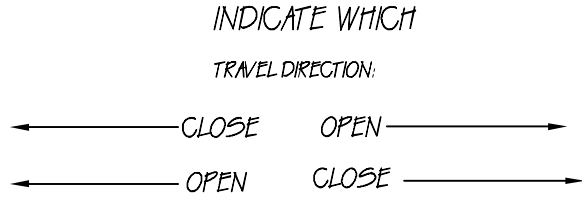
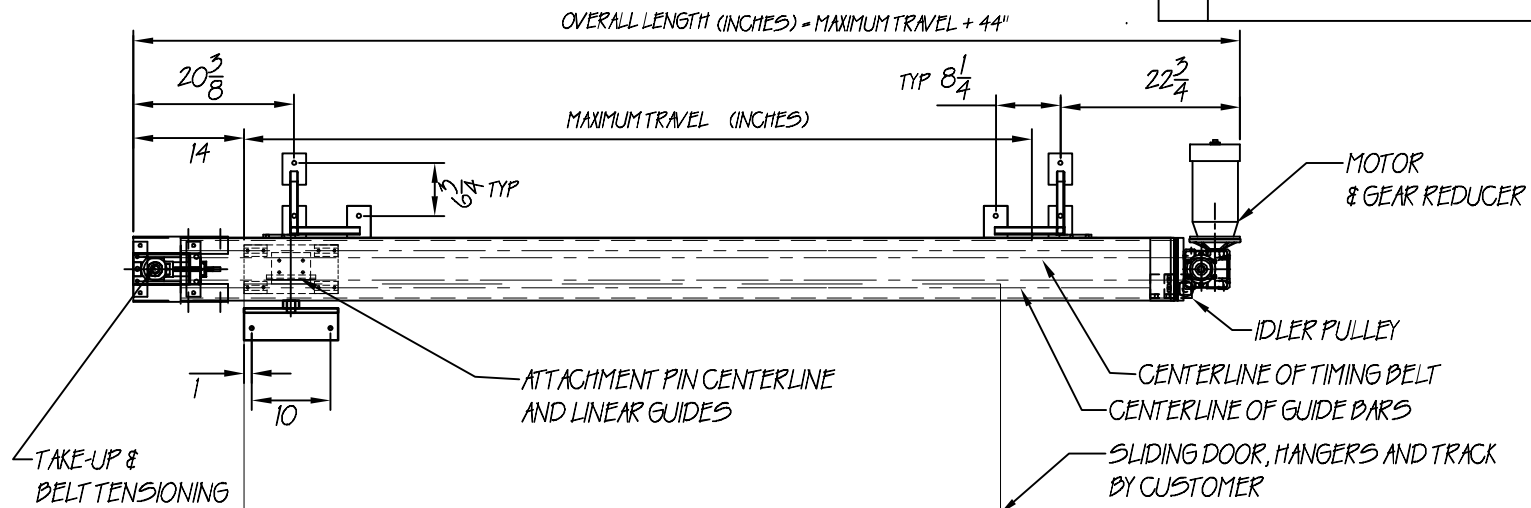

MOTOR / TAKE-UP ORIENTATION:

MOTOR RIGHT / TAKE-UP LEFT (AS SHOWN)

MOTOR LEFT / TAKE-UP RIGHT (OPPOSITE)

16 X 20 NEMA I BOX HOUSES
MOTOR CONTROL LOGIC AND POWER SUPPLY
HOOKUP



	NB-4100-1 SLIDING DOOR OPERATOR		Drawn by KPK
			Checked by XXX
	Material	Date 10-2-03	Scale 1:1
	ELEVATION/INSTALLATION DWG		
brookfield industries inc. 99 West Hillside Ave.: Thomaston, CT P: (860) 283-6211 F: (860) 283-6123 info@brookfieldindustries.com			www.bfimfg.com Drawing No/File Name DO2003R2

Tolerances	Decimal 1/8	Fractional +/- mm	Angular +/- mm
------------	-------------	-------------------	----------------

Rev.	Revision note	Date	Sign	Check
2	REVISE NOTES	5/16		

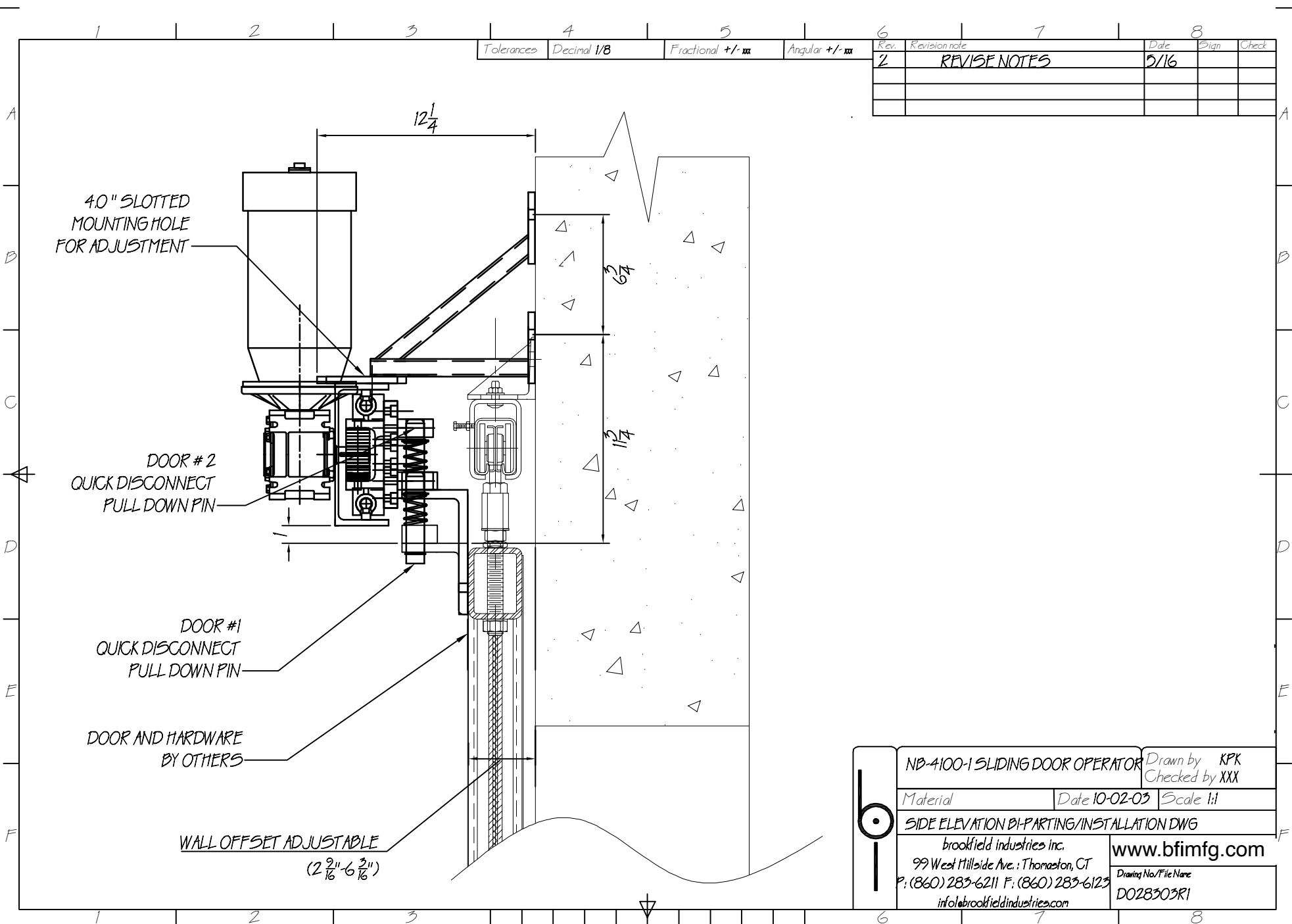

NB-4100-1 SLIDING DOOR OPERATOR		Drawn by KPK
		Checked by XXX
Material	Date 10-02-03	Scale 1:1
SIDE ELEVATION BI-PARTING/INSTALLATION DWG		
brookfield industries inc.		www.bfimfg.com
99 West Hillside Ave.: Thomaston, CT		
P: (860) 283-6211 F: (860) 283-6123		Drawing No/File Name
info@brookfieldindustries.com		DO28303R1

Tolerances	Decimal +/- 0.0005	Fractional +/- 1/32	Angular +/- 30
------------	--------------------	---------------------	----------------

Rev.	Revision note	Date	Sign	Check
1	REVISE NOTES	6/13	KPK	

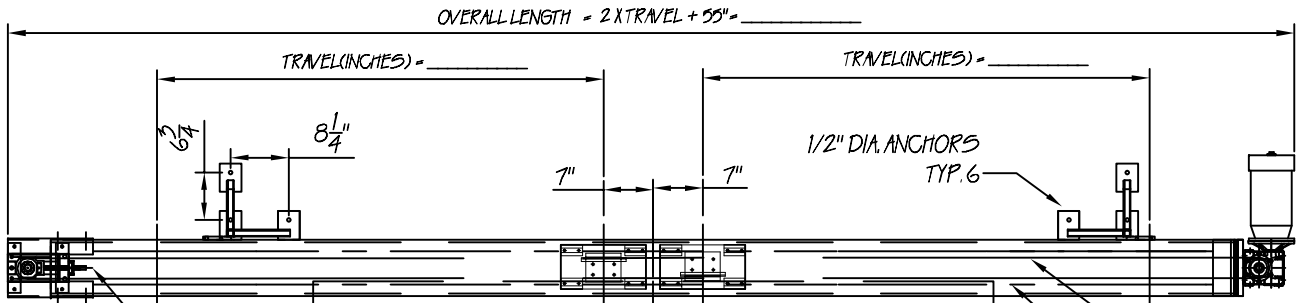

NOTES:
 TO CLOSE AND OPEN AS INDICATED, BUILD AS SHOWN. TO CLOSE AND OPEN IN OPPOSITE DIRECTION, BUILD OPPOSITE HAND

 DIRECTION CAN BE REVERSED BY SWITCHING M1 AND M2 ON MOTOR LEADS AND SWITCHING THE REV LIMIT SWITCH WIRES WITH THE FWD LIMIT SWITCH WIRES AT THE TERMINAL STRIP.

TIMING BELT TENSION ADJUSTMENT

QUICK RELEASE PIN DOOR #2

QUICK RELEASE PIN DOOR #1

CENTERLINE OF TIMING BELT
 CENTERLINE OF GUIDE BARS

SLIDING DOOR, HANGERS AND TRACK BY CUSTOMER

16 X 20 NEMA 1 BOX HOUSES
 MOTOR CONTROL LOGIC AND POWER SUPPLY
 HOOKUP

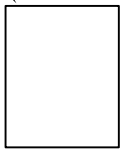

NB-4100-1 SLIDING DOOR OPERATOR		Drawn by KPK
		Checked by XXX
Material	Date 10-2-03	Scale 1:1
ELEVATION FOR BI-PARTING DOOR/INSTALLATION DWG		
brookfield industries inc. 99 West Hillside Ave. : Thomaston, CT P: (860) 283-6211 F: (860) 283-6123 info@brookfieldindustries.com		www.bfimfg.com
		Drawing No/File Name DO28303R2